

Model 100LCI-T Specifications and Dimensions

STANDARD FEATURES:

- 1 HP drive, 115 volt, 50/60 Hz, single phase, 20 amp motor
- Mixer and controls are wired and include a cord and plug
- IP55/NEMA 12 motor
- Variable speed control from 500 - 10,000 rpm (+/- 1% speed accuracy)
- Color touch screen control and display including RPM, percent of load, batch timer and temperature (up to 300°F or 150°C)
- Electronic Push-Button Lift
- Stainless Steel type 316 wetted parts
- Sturdy frame for bench mounting
- All non-Stainless Steel external surfaces coated with a white two-part epoxy paint
- Easy to disassemble and clean

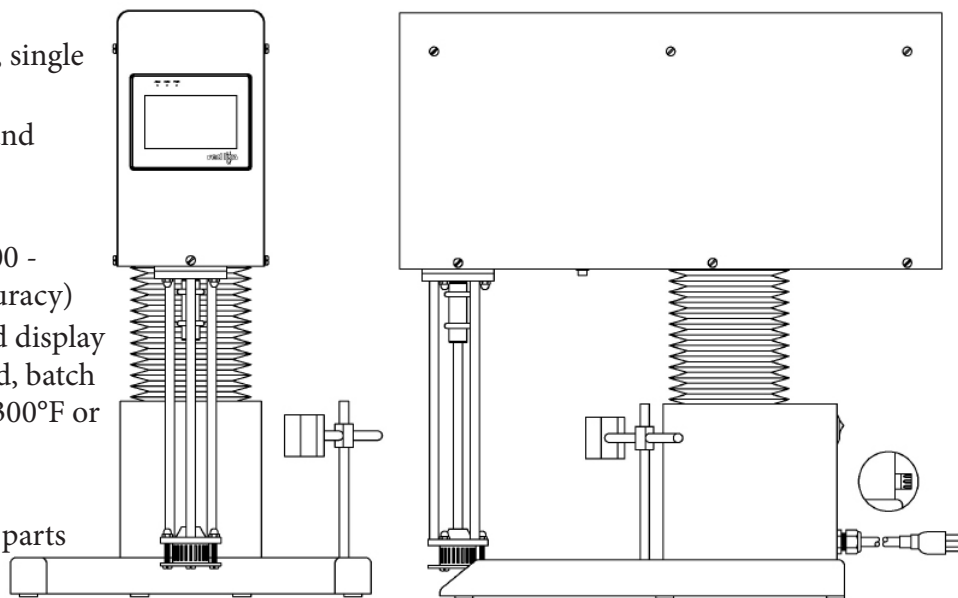

AVAILABLE MIXING ATTACHMENTS:

- HSM Attachment: High Shear Rotor/Stator attachment complete with disintegrating, slotted and fine screen stator heads. Attachment is equipped with a Teflon bushing
- Inline HSM Attachment: Inline attachment complete with disintegrating, slotted and fine screen stator heads
- HSD Attachment: High Speed Dispenser and propeller mixer attachment
- Micro HSM Attachment: High Shear Micro Rotor/Stator attachment for batches between 50 mL and 500 mL
- Quad HSM Attachment: Quad (four stage) attachment for ultra-fine emulsions and dispersions

AVAILABLE OPTIONS:

- Down-thrust propeller for standard rotor/stator attachment
- Bronze, glass-filled Teflon or Stellite bushing for standard rotor/stator attachment
- 80 mesh fine screen or large square hole stator heads for standard rotor/stator attachment
- Temperature probe with beaker clip. Temperature is displayed on the digital readout
- Vessel/Beaker clamp attachment
- Optional voltages: 190 - 230 V, 50/60 Hz
- Hastelloy product contact surfaces

Model	RPM	Overall Raised Height	Overall Lowered Height	Overall Width	Overall Length	Distance Between Feet	Water Capacity	Weight
100LCI-T	500 - 10,000	39 3/8"	24 1/2"	15"	22 5/8"	12"	0.3 - 4 gal.	62 lbs
		1000 mm	622 mm	381 mm	575 mm	305 mm	1.1 - 15 L	28 kg



CHARLES ROSS & SON COMPANY

P.O. Box 12308, 710 Old Willets Path, Hauppauge, NY 11788

• Telephone: 631-234-0500 • Fax: 631-234-0691

• Website: www.mixers.com • Email: sales@mixers.com

Model 100LCI-T Attachments

High Shear Mixer
(HSM)

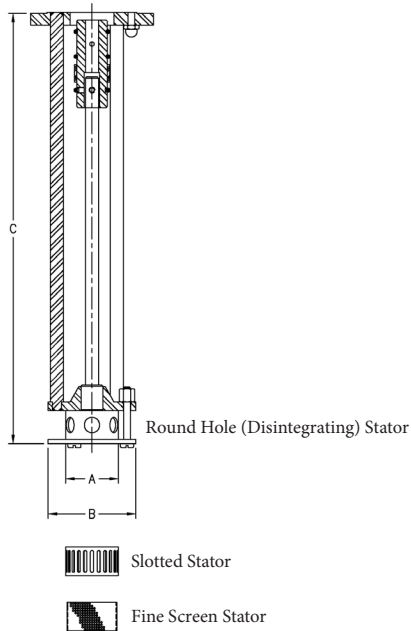

High Speed Disperser
(HSD)

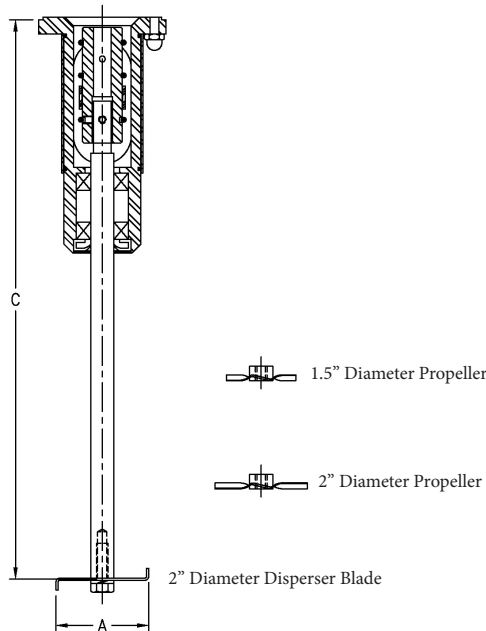

Micro High Shear Mixer
(Micro HSM)

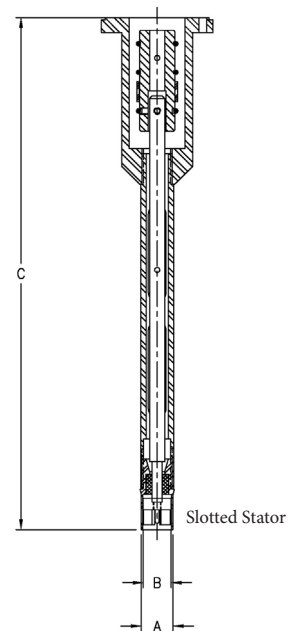

Quad High Shear Mixer
(Quad HSM)

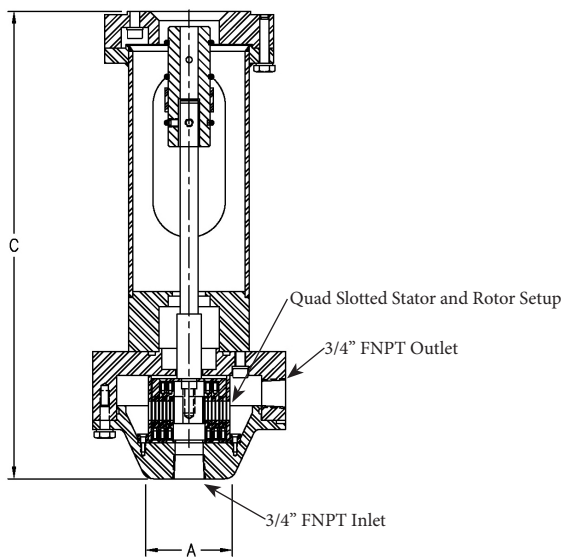

Inline High Shear Mixer
(Inline HSM)

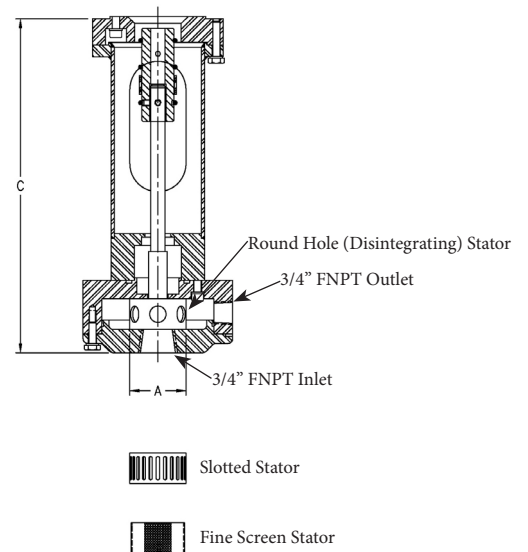

Attachment	Rotor Diameter (A)		Lower Flange Diameter (B)		Shaft Length (C)	
	Inches	Millimeters	Inches	Millimeters	Inches	Millimeters
HSM	1 3/8	34.9	2 1/2	63.5	12 5/16	312.7
HSD	2	50.8	N/A	N/A	12 1/16	306.4
Micro HSM	0.69	17.5	0.79	20	13 5/8	346.1
Quad HSM	1 3/8	34.9	N/A	N/A	9 7/8	251
Inline HSM	1 3/8	34.9	N/A	N/A	9 3/16	233